

Regular paper

A simple low-cost microcontroller-based photometric instrument for monitoring chloroplast movement

Robert Berg¹, Martina Königer², Brit-Maren Schjeide², George Dikmak³, Susan Kohler³ & Gary C. Harris^{2,*}

¹*Department of Physics, Wellesley College, Wellesley, MA 02481, USA;* ²*Department of Biological Sciences, Wellesley College, Wellesley, MA 02481, USA;* ³*Science Center, Wellesley College, Wellesley, MA 02481, USA;* **Author for correspondence (e-mail: gharris@wellesley.edu; fax: +1-781-283-3642)*

Received 24 February 2005; accepted in revised form 26 May 2005

Key words: chloroplast movement; laser scanning confocal microscopy; leaf transmittance; LogoChip; photometer

Abstract

A new microcontroller-based photometric instrument for monitoring blue light dependent changes in leaf transmission (chloroplast movement) was developed based on a modification of the double-beam technique developed by Walczak and Gabrys [(1980) *Photosynthetica* 14: 65–72]. A blue and red bicolor light emitting diode (LED) provided both a variable intensity blue actinic light and a low intensity red measuring beam. A phototransistor detected the intensity of the transmitted measuring light. An inexpensive microcontroller independently and precisely controlled the light emission of the bicolor LED. A typical measurement event involved turning off the blue actinic light for 100 μ s to create a narrow temporal window for turning on and measuring the transmittance of the red light. The microcontroller was programmed using LogoChip Logo (<http://www.wellesley.edu/Physics/Rberg/logochip/>) to record fluence rate response curves. Laser scanning confocal microscopy was utilized to correlate the changes in leaf transmission with intercellular chloroplast position. In the dark, the chloroplasts in the spongy mesophyll exhibited no evident asymmetries in their distribution, however, in the palisade layer the cell surface in contact with the overlying epidermis was devoid of chloroplasts. The low light dependent decrease in leaf transmittance in dark acclimated leaves was correlated with the movement of chloroplasts within the palisade layer into the regions previously devoid of chloroplasts. Changes in leaf transmittance were evident within one minute following the onset of illumination. Minimal leaf transmittance was correlated with chloroplasts having retreated from cell surfaces perpendicular to the incident light (avoidance reaction) in both spongy and palisade layers.

Abbreviations: EMS – ethyl methane sulfonate; LED – light emitting diode

Introduction

It has been well established that many species of photosynthetic eukaryotes can actively alter the orientation and/or position of their chloroplasts in response to the presence or absence of light signals from the environment (for recent reviews see Kagawa 2003; Wada 2003). In general, it has been

observed that under low light intensities, chloroplasts are positioned to maximize the absorption of light, while at high light intensities there is an avoidance reaction. This capability has probably evolved both to maximize the efficiency of photosynthetic light harvesting under light limiting conditions and to prevent photodamage under conditions of excess light. Some species also exhibit

non-random arrangements of chloroplasts in the absence of light signals. For example, in dark-adapted *Lemna* leaves mesophyll cell chloroplasts have been observed to cluster along the walls of the cells that do not contact the abaxial and adaxial epidermises (Haupt and Scheuerlein 1990).

Since it was first reported in the mid-19th century, and continuing to the present day, the experimental analysis of chloroplast movement has often involved the use of light microscopy utilizing both fresh and fixed/sectioned tissues (Senn 1908; Trojan and Gabrys 1996; Kagawa and Wada 2000; Takagi 2003). However, in intact multilayered leaves, tissue thickness often interferes with direct microscopic analysis of organelle movement except in the uppermost layer of relatively thin leaves (e.g. *Arabidopsis*). In more recent years this problem has been resolved by the development of confocal microscopy (Tlalka and Fricker 1999) and instruments that are capable of monitoring changes in the leaf transmission to visible light. In general, these latter instruments possess an actinic source of variable intensity blue light to drive chloroplast movement and a weak measuring beam of red light to monitor the changes in leaf transmittance as the chloroplasts move into or out of the region illuminated by the actinic light. The instruments that have been described involve a variety of electrical components, lenses, mirrors, interference filters, which make them relatively expensive, difficult to construct and maintain (Inoue and Shibata 1974; Walczak and Gabrys 1980; Brugnoli and Björkman 1992; Trojan and Gabrys 1996; DeBlasio et al. 2003; Williams et al. 2003; Kondo et al. 2004). We report here on the design and development of a relatively inexpensive, easy to construct, small, microprocessor-controlled device that is capable of measuring changes in the positioning of chloroplasts by monitoring changes in leaf transmittance utilizing light emitting and absorbing photodiodes.

Materials and methods

Plant material

Arabidopsis thaliana plants were grown for 4–5 weeks under a cycle of 12 h light ($170 \mu\text{mol photons m}^{-2} \text{ s}^{-1}$) and 12 h dark. The temperature was 25 °C during the day and 22 °C at night. The mutagenized (EMS) *Arabidopsis thaliana* seeds (M_2 Columbia) which were used to screen for

chloroplast movement mutants, were obtained from Lehle seeds.

Confocal microscopy

The 3D position and orientation of chloroplasts in leaf discs fixed with 2% glutaraldehyde was imaged by their autofluorescence (chlorophyll a fluorescence) using a laser scanning confocal microscope (LEICA TCS-NT, LEICA, Wetzlar, Germany). Chlorophyll a fluorescence was excited using a Krypton laser (568 nm, absorption 600–720 nm). The images were taken with a 40 \times oil-immersion objective. Optical sections were spaced at 1–2 μm . Each optical section was averaged over 2–8 frames. Images are presented as maximum projections of several optical sections. All images were processed using Adobe Photoshop 5.0 by applying standard methods of image optimization such as contrast and brightness adjustments. Leaves were fixed by vacuum infiltration with 2% (v/v) glutaraldehyde immediately following their removal from the photometer. The leaves remained in the glutaraldehyde solution overnight at room temperature. The leaves were then washed with H_2O and cut in half. The two halves of a given leaf were utilized to image the adaxial and abaxial surfaces with the confocal microscope.

Photometer components

With the exception of the Blue and Red LED (Unitech Systems Inc./LC LED Inc.; www.lc-led.com), all the photometer components were purchased through Digi-Key (www.digikey.com/).

Part	Part Number
npn phototransistor	PNA1801L-ND
npn transistor	2N3904D26ZCT-ND
7805 5-volt regulator	296-13996-5-ND
RS232 line driver	MAX233CPP-ND
Microcontroller	PIC16F876-20I/SP-ND
20 MHz resonator	X909-ND
Pushbutton	SW400-ND
Bi-color LED	160-1058-ND
power switch	EG1903
47 μF capacitor	P2017-ND
0.1 μF capacitor	399-2127-ND
1 K resistor	1.0KQBK-ND

Part	Part Number
10 K resistor	10KQBK-ND
330 ohm resistor	330QBK-ND
2.7 K resistor	2.7KQBK-ND
150 ohm resistor	150QBK-ND
serial connector	209F-ND
1 K potentiometer	3852a-162-102a-nd
connector housing 10 position	A26971-ND
connector socket crimp	A3006-ND
Mega-Bright Blue and Red LED	N500TBR4D

Results and discussion

A new microcontroller-based photometer has been constructed to monitor blue light dependent changes in chloroplast positioning within the cells of intact leaves. Previous work has established that the positions of chloroplasts within the leaf's mesophyll cells can profoundly impact the optical properties of the leaf (Zurzycki 1961; Kagawa et al. 2001). One of these properties, the leaf's transmittance, has been used to monitor the dynamics of chloroplast movement (Zurzycki 1961; Trojan and Gabrys 1996; Jarillo et al. 2001; Williams et al. 2003; DeBlasio et al. 2004). The instrument described here, which also measures changes in leaf transmittance, was designed based on the double-beam technique reported by Walzack and Gabrys (1980). In the double-beam technique, actinic blue light is used to induce chloroplast movement which is then monitored by measuring changes in the transmission of a weak red measuring beam in the presence of the much more intense actinic blue light. Traditionally such measurements have relied on one or more of the following: optics filters (colored and neutral density), fiber optics, phase sensitive detectors (lock-in amplifiers), grating based spectrophotometers, integrating spheres, spectroradiometers (Inoue and Shibata 1974; Walzack and Gabrys 1980; Brugnoli and Björkman 1992; Trojan and Gabrys 1996; DeBlasio et al. 2003; Kondo et al. 2004). The instrument described in this report uses a different approach.

The basic geometry of the photometer is shown in the Figure 1. The blue and the red light are

provided by a bicolor LED that contains separate LEDs mounted in very close proximity to one another, producing two beams that overlap almost perfectly. The LED is held in a mount less than 1 mm from the surface of the leaf. The intensity of the transmitted light is measured with a phototransistor placed on the other side of the leaf, close to the leaf surface and directly opposite to the LED. With the arrangement shown, the voltage produced at the collector of the phototransistor is directly proportional to the intensity of the incident light. The spectral peak of the red diode was at 638 nm, with a full width at half maximum of 20 nm. The spectral peak of the blue diode occurred at 467 nm with a full width at half maximum of 35 nm. The diodes come mounted in a diffused lens casing that provides uniform illumination over a 30° angle.

An inexpensive microcontroller (Microchip PIC16F876 running at 20 MHz) was used to control when each LED was on or off. The key to our method, summarized by the timing diagram shown in Figure 2, hinges on the microcontroller's ability to precisely and independently turn on and off the blue and red LEDs and to synchronize this with a transmission measurement. In a typical experimental protocol once every 60s the blue LED was turned off for 100 μ s. During this brief window the red LED was turned on and the transmission was recorded by the microcontroller's built-in 10-bit analog-to-digital converter. The results of the

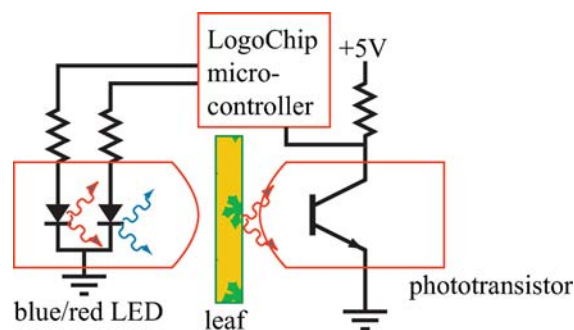

Figure 1. Schematic diagram of a photometer designed to measure blue light dependent chloroplast movement by monitoring changes in the leaf transmission. The leaf transmittance changes were analyzed by measuring the changes in intensity of a weak red measuring light after its passage through the leaf. The source of both the red measuring beam and the actinic light to drive chloroplast movement was a photodiode controlled by a LogoChip microcontroller. The changes in the intensity of the red light were measured by a phototransistor that was located directly opposite the source photodiode.

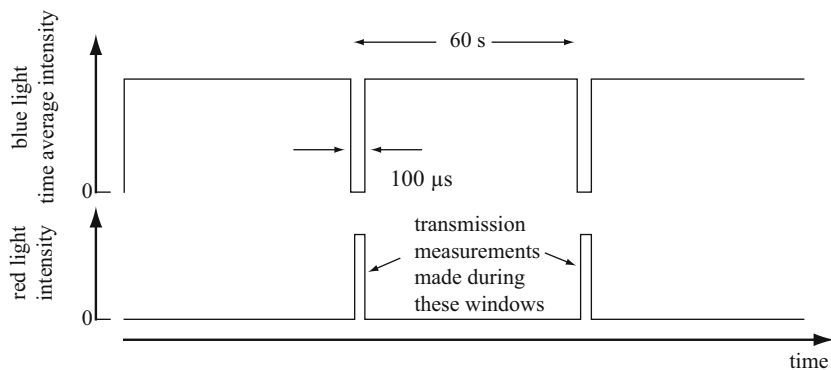

Figure 2. Representative timing regimen (on/off cycles) for the photodiode in the newly designed instrument for measuring blue light dependent chloroplast movement by monitoring changes in the leaf transmission (see Figure 1 for a schematic diagram). The red measuring beam was turned on during a brief window created by turning the blue actinic light off for 100 μs .

transmission measurements were stored on the LogoChip and then later fed through a serial connection to a desktop computer. Note that, because in this scheme the red and blue lights are not on at the same time, the usual difficulties associated with trying to extract the weak 'red signal' in the presence of a strong 'blue signal' are no longer present. Therefore we do not need to employ any filters, spectrometers, or other devices such as a lock-in amplifier. Since the red light is on for less than 0.0002% of the time we are able to set the peak intensity of the red light relatively high (thus making it easy to detect the transmitted red light with a simple phototransistor) while still keeping the *average* fluence rate of the red beam extremely low (max of $0.0124 \mu\text{mol photons m}^{-2} \text{s}^{-1}$). Our data suggest (Figure 3) that only the average fluence rate of the red light has to be kept low in order to insure that the red beam is non-actinic. Also, since the blue light is turned off for periods of the time that are many orders of magnitude shorter than the time scale for the chloroplast movement, the effective fluence rate of the blue light is maintained at a constant level throughout the measurements. The output of the red LED and the phototransistor were very stable ($<0.06\%$ change in recorded output) during the intervals of time required for these experiments (maximum of 24 h).

Since we do not place any wavelength selective filters in front of the phototransistor, any long-lived chlorophyll a fluorescence induced by the actinic blue light could erroneously contribute to the % transmission measurements. However, we do not believe this to be a problem, since we have programmed in a delay of several tens of micro-

seconds after turning the blue light off before making the transmission measurement. This has also been verified experimentally by showing that when measurements were made without the red measuring light on there were no signals detectable by the phototransistor.

We programmed the microcontroller to automatically record fluence rate response curves to monitor how chloroplasts move in response to changes in the fluence rate of the blue light. In a typical run (Figure 3), the transmission of the red light was monitored over the course of 19 h, and the blue light fluence rate was changed every hour. We made use of a simple pulse width modulation (PWM) scheme to vary the time average fluence rate of the blue light. The PIC16F876 has a built-in PWM module, which simplified this task. In this scheme, the blue light was turned rapidly on and off at a frequency of 1.25 kHz and the *time average* fluence rate of the blue light was adjusted once an hour by changing the *duty cycle* (defined as the percentage of the time that the light is on). We can vary the duty cycle from 0 to 100% in 0.1% increments. With a duty cycle of 100% the fluence rate was $230 \mu\text{mol photons m}^{-2} \text{s}^{-1}$. Since the PIC16F876 microcontroller has five built-in analog-to-digital converters, it was straightforward to control five different LED/phototransistor pairs and thus we have been able to measure five leaves at the same time. A detailed schematic drawing of this circuit is shown in a supplementary diagram. Also we are developing a single-channel battery-powered highly portable version of the instrument.

The native programming language for the PIC16F876 microcontroller consists of a set of

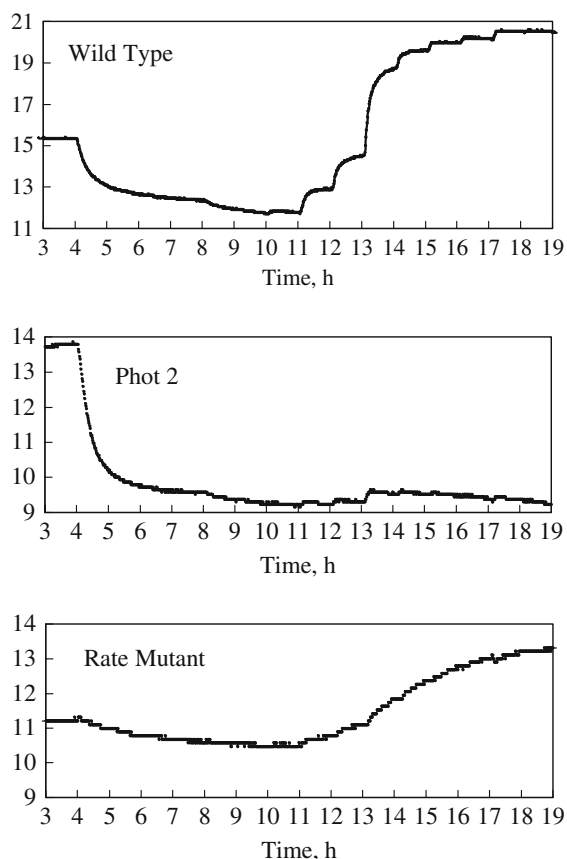

Figure 3. Blue light dependent changes in the % transmittance in a dark-adapted (overnight) *A. thaliana* leaves using the newly designed photometer. Dark-adapted leaves were placed in the leaf clip and for the first 4 h the transmission was measured in the dark. The leaves were then exposed to $0.1 \mu\text{mol photons m}^{-2} \text{s}^{-1}$ for 3 h. After that the blue intensity was increased every hour (7 h: $0.2 \mu\text{mol photons m}^{-2} \text{s}^{-1}$; 8 h: $0.4 \mu\text{mol photons m}^{-2} \text{s}^{-1}$; 9 h: $0.8 \mu\text{mol photons m}^{-2} \text{s}^{-1}$; 10 h: $1.6 \mu\text{mol photons m}^{-2} \text{s}^{-1}$; 11 h: $5 \mu\text{mol photons m}^{-2} \text{s}^{-1}$; 12 h: $10 \mu\text{mol photons m}^{-2} \text{s}^{-1}$; 13 h: $30 \mu\text{mol photons m}^{-2} \text{s}^{-1}$; 14 h: $40 \mu\text{mol photons m}^{-2} \text{s}^{-1}$; 15 h: $50 \mu\text{mol photons m}^{-2} \text{s}^{-1}$; 16 h: $60 \mu\text{mol photons m}^{-2} \text{s}^{-1}$; 17 h: $90 \mu\text{mol photons m}^{-2} \text{s}^{-1}$; 18 h: $100 \mu\text{mol photons m}^{-2} \text{s}^{-1}$). The traces are of wild type leaves, a mutant in which *phot2* had been knocked out and an uncharacterized EMS mutant.

only 35 machine language instructions. While it certainly would have been possible to program our instrument directly in this native language, we took what we believe to be a simpler approach, employing a higher-level programming environment called LogoChip Logo. To use LogoChip Logo, we make use of a PIC16F876 microcontroller that has been transformed into a LogoChip by downloading onto the microcontroller the ‘LogoChip virtual machine’ which is a program

written in the native machine language. We can develop programs using a special version of the Logo programming language on a computer and then download them to the LogoChip. LogoChip Logo combines all the power and elegance of the Logo programming language with the ability to directly configure and control the individual pins on the LogoChip. More details on the LogoChip environment can be found at <http://www.wellesley.edu/Physics/Rberg/logochip/>. There are also a number commercially available higher-level programming environments for microcontrollers that would be perfectly suitable for the purpose of controlling the instrument described here. For example, the Basic Stamp, which is available from Parallax Inc. (www.parallax.com), or the OOPIC, which is distributed by Savage Innovations (www.oopic.com).

The LED and phototransistor shown in the schematic diagram in Figure 1 were mounted on a structure constructed out of Plexiglas (Figure 4). To reproducibly and stably position a leaf between the LED and phototransistor, a spring-loaded aluminum clip was constructed with 5 mm openings drilled on each side. The holes were positioned directly opposite to one another to allow for the leaf to be illuminated and the transmitted light to be detected by the phototransistor. Prior to mounting a leaf within the clip a moistened rectangular strip of filter paper, with a circular opening that was the same size as those in the aluminum leaf clip, was pressed next to the detached leaf. The circular opening in the filter paper wick was aligned with the openings in the aluminum clip so as not to impede the incident light and the other end was immersed in a reservoir of water with the petiole of the leaf in the Plexiglas leaf clip holder. This prevented any detectable water stress during the prolonged times (19 h) required for some experiments. It was also found that the water reservoir can be used as an effective means to feed inhibitors etc. to the leaf. An inlet for gas mixtures was also incorporated into the design to test the effects of various gas mixtures (i.e. various CO_2 and or O_2 partial pressures) on chloroplast movements. The aluminum leaf clip was held tightly in the Plexiglas holder by a screw clamp.

Each leaf clip was calibrated by placing neutral density filters of known % transmittance in the location in the clip where the leaf was normally positioned (Figure 4). A least squares analysis of

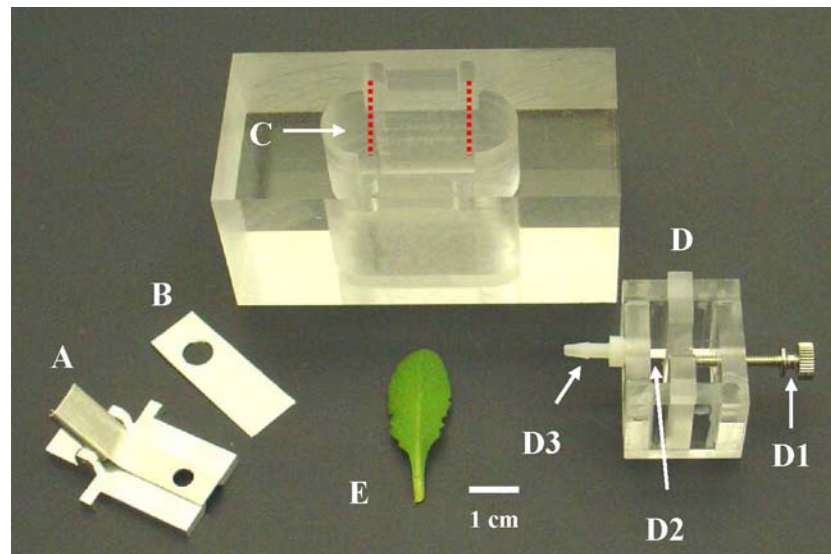

Figure 4. Non-electronic components of the newly designed photometer used to measure blue light dependent chloroplast movement by monitoring changes in the leaf transmission (see Figure 1. for a schematic diagram). (A) Spring loaded aluminum leaf clip with circular openings for light entry and exit; (B) Filter paper wick that was water saturated and placed on the adaxial leaf surface and held in position by the leaf clip. The circular opening on the wick was positioned over the circular opening on the leaf clip to allow for light penetration onto the leaf surface. The bottom of the wick was below the surface of the water in the reservoir and drew water by capillary action to hydrate the leaf and supplement water drawn through the leaf petiole; (C) Plexiglas water reservoir. Pairs of dotted lines on the reservoir indicate where the Plexiglas leaf clip holder was positioned; (D) Plexiglas leaf clip holder. (D1) Thumb screw to secure leaf clip in the holder in the slot marked as D2; (D3) Gas inlet to allow for different gas mixtures to pass over the leaf surfaces. The openings for the photodiode and phototransistor were aligned and located immediately below the gas inlet and the thumb screw. (E) Mature leaf of *A. thaliana*.

the linear change in % transmission *versus* phototransistor output generated an equation that was used to calibrate each clip. This was done to correct for potential differences in LED intensity, phototransistor sensitivity, and alignment of components in the clip.

Figure 3 shows the results of a series of experiments designed to measure the blue light dependent changes in leaf transmittance in wild type and mutant *Arabidopsis* leaves. All of the dark-adapted leaves exhibited little or no apparent change in leaf transmittance in response to the periodic flashes of the weak red measuring beam. For wild type, the exposure of the leaves to a series of low intensity blue light treatments led to corresponding step-wise decreases in leaf transmittance. The minimal leaf transmittance was generally 20% lower than the dark acclimated transmittance. An increase in leaf transmittance was first evident at a blue light intensity of approximately $5 \mu\text{mol photons m}^{-2} \text{s}^{-1}$ and marked the apparent transition from the chloroplast accumulation reaction to avoidance. The step-wise increases in leaf transmittance saturated at approximately $90 \mu\text{mol photons}$

$\text{m}^{-2} \text{s}^{-1}$ light intensity. The nature and the quality (low signal to noise ratio) of the results obtained with this photometer are similar to those previously reported for *Arabidopsis* (Trojan and Gabrys 1999; Jarillo et al. 2001; DeBlasio 2004), which reveals the effectiveness of the instrument for these types of measurements.

The results with the phototropin 2 (*phot2*) mutant are similar to those previously reported (Jarillo et al. 2001) and reflect the suggested role for *phot2* in mediating the high fluence avoidance reaction. The photometer has also been utilized to screen EMS-treated *Arabidopsis* seeds for potential chloroplast movement mutants (Figure 3). The data show the efficacy of the photometer for this type of work as it has allowed us to identify a rate mutant that appears to influence both the accumulation and avoidance reaction. In contrast to screening methods that have employed a stencil or partial light blockage techniques (Kagawa et al. 2000), this instrument will allow researchers to more effectively screen for subtle kinetic mutants of chloroplast movement. The genetic characterization of this mutant is currently underway.

In an effort to make sure that the changes in leaf transmission induced by the blue LED were really due to changes in the chloroplast position, leaves were fixed in 2% (v/v) glutaraldehyde and analyzed by laser scanning confocal microscopy. It was observed that in dark-adapted wild type leaves the palisade (Figure 5A) and spongy mesophyll cells (Figure 5B) exhibited marked differences in the intracellular distribution pattern of chloroplasts. In the palisade layer the region of the cell in which the overlying cell wall is in direct contact with the adaxial epidermis was devoid of chloroplasts. The remainder of the intracellular surfaces was densely packed with chloroplasts.

Under low intensity blue light some of the chloroplasts of the palisade mesophyll

(Figure 5C) moved to positions on the cell surfaces that are in contact with the adaxial epidermis leading to a more uniform distribution of chloroplasts along all of the cell wall surfaces of these cells. There was little or no evident net movement of the spongy chloroplasts (Figure 5D) under these low light intensities when compared to the dark position. Under higher light intensities the spongy cell chloroplasts (Figure 5E) retreated to the sidewalls and the palisade mesophyll chloroplasts (Figure 5F) showed a clear light avoidance reaction.

Similar results were previously reported by Trojan and Gabrys (1999) using thin cross sections of fixed *Arabidopsis* leaves and conventional light microscopy. Our work with *Arabidopsis* has served,

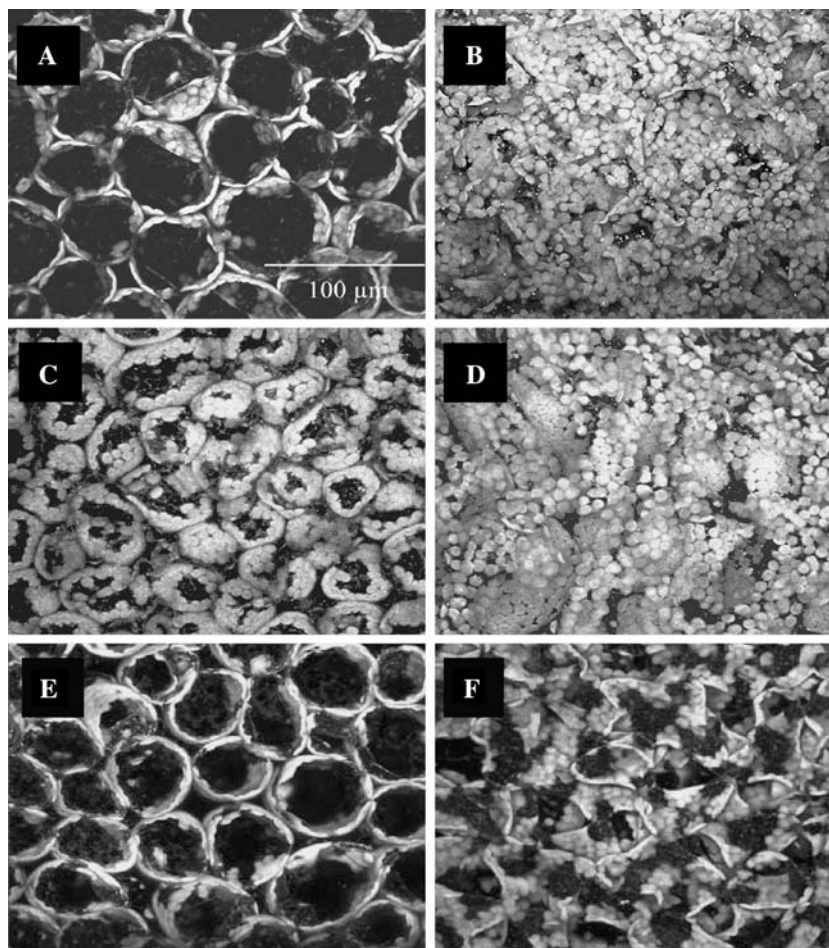

Figure 5. Chloroplast distribution in *A. thaliana* palisade (A, C, E) and spongy mesophyll cells (B, D, F) after different light treatments in the newly designed photometer. Leaves were either dark-adapted for 12 h (A, B) or exposed to low light ($0.8 \mu\text{mol photons m}^{-2} \text{s}^{-1}$) for one hour (C, D) or high light ($100 \mu\text{mol photons m}^{-2} \text{s}^{-1}$) for 40 min (E, F) in the newly designed photometer. The leaves were fixed in 2% glutaraldehyde. The confocal images were acquired from the regions of the leaf that were exposed to the blue light in the opening of the leaf clip. The images are displayed as maximum projections generated from optical slices spaced at 1–2 μm . Scale bar, μm .

in general, to corroborate the results observed by Gabrys and Trojan (1999). However, the confocal imaging, which allows us to more readily view the three-dimensional distribution of chloroplasts in the cells, has revealed that the accumulation reaction seen following a low light exposure of dark-adapted leaves is due to chloroplast movements primarily within the palisade cells. This, and asymmetrical positioning of chloroplasts in the palisade cells of dark-adapted *Arabidopsis* leaves, suggests that there are biochemical differences between these tissues that directly impact chloroplast positioning. Nishio et al. (1993) have previously reported some of the physiological and biochemical differences between the palisade and spongy mesophyll in spinach leaves, including chlorophyll, carotenoids and rubisco.

This newly designed photometer described in this report can be easily programmed to record blue light dependent changes in leaf transmission over extended periods of time. It is inexpensive and exhibits little complexity in both its design and construction. The flexibility in the programming environment allows the researcher an almost limitless number of options with regard to experimental variations (i.e. fluence rate or the timing of light pulses) in the blue and/or red light exposures. For example, by decreasing the time intervals between the red light (measuring beam) pulses we were able to obtain more accurate estimates of the timing of the initial response of dark-adapted leaves to blue light exposure. There is also a very low heat load from the diodes eliminating the need for active leaf cooling and allowing the diodes to be positioned very close to the leaf. The multi-channel prototype described here is capable of acquiring data from five different leaves at the same time. Given the ease of construction and the low cost it would be relatively easy to build several of these multi-channel devices to facilitate mutant screening (Figure 6). It also could readily be made portable allowing the leaf clip to be utilized on non-detached leaves. However, it is also important to point out that while the device could be made portable, it is not a field instrument. It would not be able to deal with either background solar radiation or marked ambient temperature fluctuations (diode emission can be temperature sensitive, both in wavelength and magnitude of emission). Willams et al. (2003) have developed a battery-powered device

for measuring chloroplast movement in the field. They used a Peltier module to control diode temperature and a lock-in amplifier to prevent background solar illumination from influencing the light detector used to measure the % transmission of the red measuring beam.

Although there are some inherent design limitations, we believe this device will facilitate the study of the environmental, chemical and genetic factors that influence changes in leaf transmittance and thereby significantly contribute to a further understanding of the mechanisms of chloroplast positioning.

Acknowledgements

Support for this research was provided by grants to MK from Brachman-Hoffman, Fiske Research Award and the Howard Hughes Medical Institute. We would like to thank Dr Winslow Briggs of the Carnegie Institution of Washington, Stanford, CA. for his kind gift of the phototropin mutant used in this study. We would also like to acknowledge the contributions of Saroj Fleming and Marlena Brown, Wellesley College undergraduates supported by Wellesley College Minority Mentorship Program. The LogoChip work was supported by an NSF grant CDA-9616444 to RB.

References

- Bugnoli E and Björkman O (1992) Chloroplast movements in leaves: influence of chlorophyll fluorescence and measurements of light-induced absorbance changes related to Δ pH and zeaxanthin formation. *Photosynth Res* 32: 23–35
- DeBlasio SL, Mullen JL, Luesse DR and Hangarter RP (2003) Phytochrome modulation of blue light-induced chloroplast movements in *Arabidopsis*. *Plant Physiol* 133: 1471–1479
- Haupt W and Scheuerlein R (1990) Chloroplast movement. *Plant Cell Environ* 13: 595–614
- Inoue Y and Shibata K (1974) Comparative examination of terrestrial plant leaves in terms of light-induced absorption changes due to chloroplast rearrangements. *Plant Cell Physiol* 15: 717–721
- Jarillo JA, Gabrys H, Capel J, Alonso JM, Ecker JR and Cashmore AR (2001) Phototropin-related NPL1 controls chloroplast relocation induced by blue light. *Nature* 410: 952–954
- Kagawa T and Wada M (2000) Blue light-induced chloroplast relocation in *Arabidopsis thaliana* as analyzed by microbeam irradiation. *Plant Cell Physiol* 41: 84–93

- Kagawa T, Sakai T, Suetsugu N, Oikawa K, Ishiguro S, Kato T, Tabata S, Okada K and Wada M (2001) *Arabidopsis* NPL1: a phototropin homolog controlling the chloroplast high-light avoidance response. *Science* 291: 2138–2141
- Kagawa TJ (2003) The phototropin family as photoreceptors for blue light-induced chloroplast relocation. *Plant Res* 116: 77–82
- Kondo A, Kaikawa J, Funaguma T and Ueno O (2004) Clumping and dispersal of chloroplasts in succulent plants. *Planta* 219: 500–506
- Nishio JN, Sun J and Vogelmann TC (1993) Carbon fixation gradients across spinach leaves do not follow internal light gradients. *Plant Cell* 5: 953–961
- Park Y-I, Chow WS and Anderson JM (1996) Chloroplast movement in the shade plant *Tradescantia albiflora* helps protect photosystem II against light stress. *Plant Physiol* 111: 867–875
- Tlalka M and Fricker M (1999) The role of calcium in blue-light-dependent chloroplast movement in *Lemna trisulca* L. *Plant J* 20: 461–73
- Senn G (1908) Die Gestalts und Lageveränderung der Pflanzenchromatophoren. W. Engelmann, Leipzig, Germany
- Takagi S (2003) Actin-based photo-orientation movement of chloroplasts in plant cells. *J Exp Biol* 206: 1963–1969
- Tlalka M and Fricker M (1999) The role of calcium in blue-light-dependent chloroplast movement in *Lemna trisulca* L. *Plant J* 20: 461–473
- Trojan A and Gabrys H (1996) Chloroplast distribution in *Arabidopsis thaliana* (L) depends on light conditions during growth. *Plant Physiol* 111: 419–425
- Wada M, Kagawa T and Sato Y (2003) Chloroplast movement. *Annu Rev Plant Biol* 54: 455–468
- Walczak T and Gabrys H (1980) New type of photometer for measurements of transmission changes corresponding to chloroplast movements in leaves. *Photosynthetica* 14: 65–72
- Williams WE, Gorton HL and Witiak SM (2003) Chloroplast movements in the field. *Plant Cell Environ* 26: 2005–2014
- Zurzycki J (1961) The influence of chloroplast displacement on the optical properties of leaves. *Acta Soc Bot Pol* 26: 157–175